

NEW RENAULT DUSTER

year
warranty



*under Renault Forever program, for detailed t&c visit [renault.co.in](https://www.renault.co.in).

the icon is back

Iconic and distinctive, the new Renault Duster returns, enhanced with the best. Its sculptural design, accentuated by Renault's new aesthetic codes, amplifies its presence. Inside, a complete transformation ushers in a refined and technological style. The openR link multimedia system with Google built-in⁽¹⁾ and the electric panoramic sunroof offers modernity crafted for your comfort.



Experience exclusive driving pleasure on your journeys with the Turbo TCe 160 engine paired with a 6-speed DCT.

**25.65 cm (10.1")
openR link
multimedia
system**

**Google
built-in⁽¹⁾**

**electric
panoramic
sunroof**

**turbo TCe 160
engine with
6-speed DCT**

**electric and
ventilated
front seats**

**17 advanced
driver-assistance
systems**

⁽¹⁾ all Google brands are trademarks of Google LLC. Depending on countries.

interactive menu

01. design

02. multimedia

03. on-board experience

04. driving pleasure

**05. advanced driver-
assistance systems**

06. customisation

pdf to download



equipment and engines



accessories

the icon reinvented

New Renault Duster rewrites its legend in a whole new way. Modern, sophisticated design with powerful presence featuring an exclusive grille, enhanced ground clearance, and a muscular body. The iconic launch edition elevates this stance with a unique Himalayan inspired side embellisher, specific iconic yellow door decal, and specific iconic yellow accents on the front grille, tailgate and roof bar.



The enlarged grille with Duster emblem along with signature front & rear LED lights enhance the bold stance of the SUV. The 45.72 cm (18") alloy wheels add a powerful feel to its silhouette.



Sleek rear end showcases the features of a sophisticated SUV: LED horizontal rear light bar for enhanced visibility and protective skid plates.



With 212 mm of ground clearance, the SUV is ready for uneven roads and every terrain you take it on. Approach angle of 26.9° and departure angle of 34.7° help tackle steep slopes and obstacles with confidence.

distinguished interior

The driver centric cockpit is designed for enveloping comfort, featuring front ventilated seats and leatherette interior. Yellow accents highlight the mountain jade leatherette wrap upholstery, complemented by carbon-finish detailing on the dashboard and door inserts. The steering wheel and armrests extend these signature yellow design touches from the exterior.



[configure and order →](#)

openR link multimedia system with Google built-in

Enjoy connectivity with the openR link multimedia and integrated Google services⁽¹⁾. Access Google Maps directly on the 25.65 cm (10.1") openR link multimedia system for smooth and intuitive navigation. Take control with Google Assistant and explore your favourite apps available via Google Play.



Closed road, new direction of traffic, roadworks... always take the best route with Google Maps integrated into the system, delivering navigation even without a smartphone.



With the voice assistant, simply say "Hey Google..." Talk to it to plan a trip, check your schedule, or turn on/off the AC.



Explore multimedia apps including Prime Video, Radioplayer for Renault, Youtube Music, Spotify, Amazon Music and exclusive content via Google Play.



Prime Video is a streaming app that brings stories from around the world to your screen. From exclusive Amazon Originals to global hits, Prime Video lets you watch what you love, when you want.



YouTube Music you stream songs, albums, and playlists with smart recommendations that keep every drive entertaining.



take the road while listening to playlists, and much more, with **Amazon Music**, included with your Amazon Prime subscription.

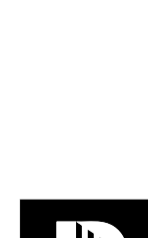

Radioplayer for Renault is a smart radio app designed for the road. It brings together live stations, podcasts, and music, all in one place. Stay connected, entertained, and in control while you drive.



Spotify brings millions of songs, curated playlists, and podcasts together to give every journey the perfect soundtrack.

⁽¹⁾Google, Google Play, Google Maps, Waze, and other marks are trademarks of Google LLC. depending on countries.

humanized technology

Stay connected on every drive with wireless smartphone replication that brings your apps, navigation and media directly to the vehicle interface. Renault connected services on the My Renault app give you easy access to key vehicle information and useful controls even when you are away from the car. A clear TFT driver display and wireless smartphone charging add further convenience.



The 26.03 cm (10.25") TFT driver display presents all the data the driver needs at a glance. Essentials are available everywhere, at any time, including map on driver display.



Driver and passengers can set separate temperatures with dual zone AC, while a clean air display tracks real-time cabin air quality. 48 colour ambient lighting subtly shift to match selected drive modes for a responsive driving experience.



[configure and order →](#)

new standards of comfort

The driver-centric cockpit includes a tilted display dashboard with dual openR screens and an elevated central console with e-shifter. For ultimate driving comfort on every journey, take a seat in electric & ventilated front seats with 6-way adjust and manual lumbar adjustment. Immerse yourself in a rich audio experience with six speakers distributed throughout the cabin.



Electric panoramic sunroof designed to bring all the surrounding natural light into the cabin.



Unlock convenience at a single touch with the electric powered tailgate, designed for fluid, hands-free operation. The low loading edge eliminates heavy lifting and ensures ease of use.

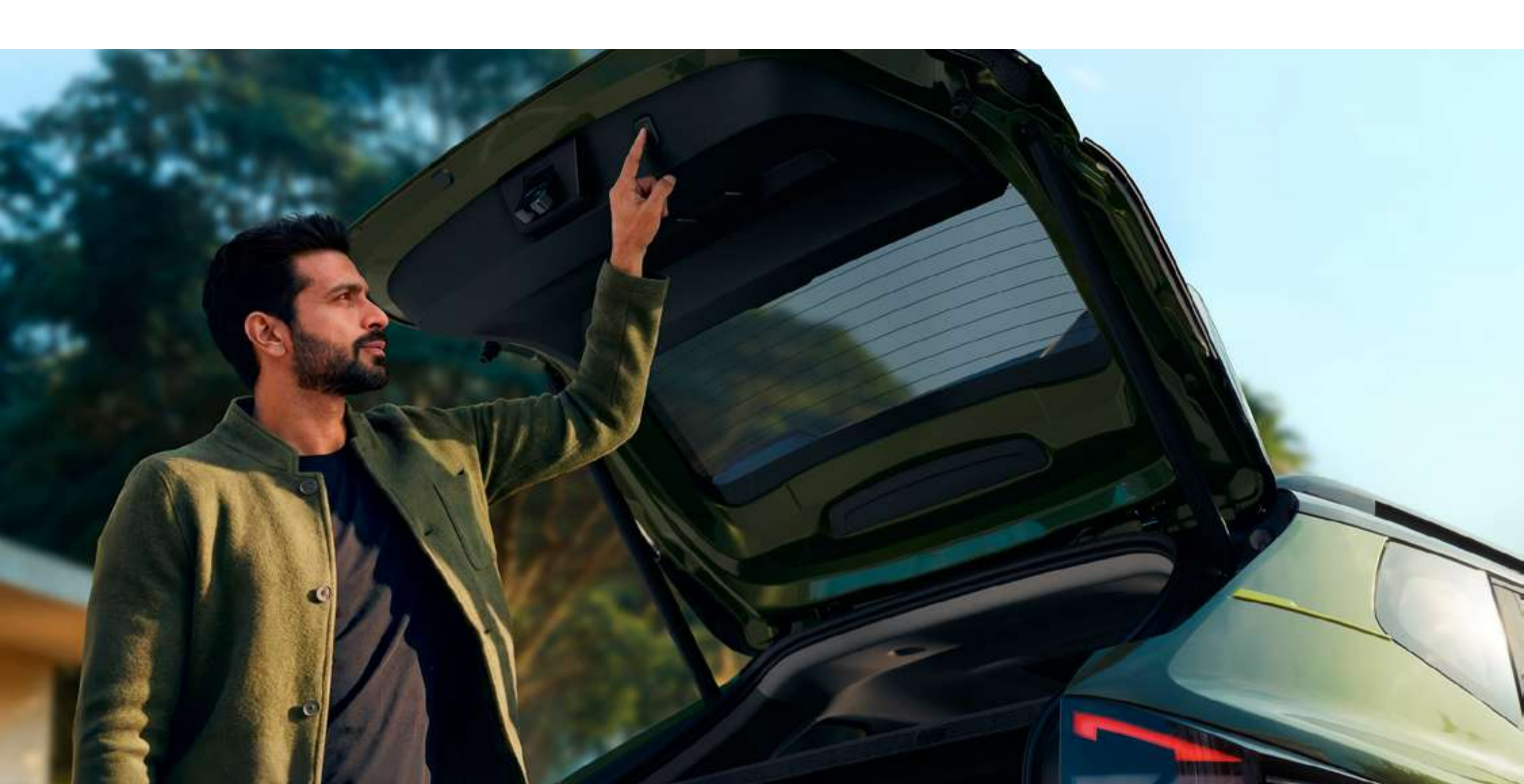

From weekend escapes to daily runs, the 700L* boot space handles it all with ease. It is a masterclass in spatial design, providing the freedom to pack for every possibility.



*518L till parcel shelf and 700L till roof

[configure and order →](#)

Turbo TCe 160

The turbo TCe 160 engine delivers a strong combination of performance and responsiveness with 163 ps of power output and 280 Nm of torque. Offering a 6-speed DCT with wet clutch and a 6-speed manual transmission, the new Renault Duster ensures smooth acceleration and confident control.

gearbox

6-speed DCT

6-speed MT

Nm torque

280

maximum power

163 ps



[configure and order →](#)

05. advanced driver-assistance systems



17 advanced driver-assistance systems



adaptive cruise control with stop & go
The system uses the front radars and cameras to maintain the cruising speed as long as the selected following distance is respected. It brakes to keep that distance, if necessary until the vehicle comes to a complete stop, and accelerate back to the cruising speed as long as the following distance is maintained.



360° around view 3D camera
The 4 cameras, whose images recreate the vehicle's direct environment 360° around it, allow you to maneuver effortlessly in complete safety.



active emergency braking system - urban/pedestrian/cyclist
The camera and radar sensor provide a warning and intervene to avoid any collisions with pedestrian, cyclist or vehicle.



lane keep assist
Applies a correction to the steering wheel to bring the vehicle back into its lane.



traffic sign recognition
The system uses the front camera, combined with connected map data, to identify the current speed limit. The speed limit is displayed on the vehicle's driver display panel.



blind spot warning
Enabled at speeds over 15 km/h, this system uses warning lights to alert you to the presence of vehicles that are not visible in your field of vision.

driving assistance

- cruise control
- speed limiter
- adaptive cruise control with stop & go
- auto high/low beam
- hill start assist
- distance warning alert

parking assistance

- rear parking assist
- front parking assist
- side parking assist
- rear view camera
- 360° around view 3D camera

security assistance

- blind spot warning
- traffic sign recognition
- active emergency braking system - urban/pedestrian/cyclist
- lane departure warning
- lane keep assist
- driver attention alert

[configure and order →](#)

06. customisation

colours



mountain jade green



pearl white



moonlight silver



stealth black



sunset red



river blue

configure and order →

06. customisation

dual-tone colours



mountain jade green with stealth black



pearl white with stealth black



sunset red with stealth black



river blue with stealth black

colour variants	authentic	evolution	techno		techno+		iconic		iconic launch edition	
	single tone	single tone	single tone	dual tone	single tone	dual tone	single tone	dual tone	single tone	dual tone
pearl white	■	■	■	■	■	■	■	■	-	-
moonlight silver	■	■	■	-	■	-	■	-	-	-
stealth black	■	■	■	-	■	-	■	-	-	-
river blue	-	-	■	■	■	■	■	■	-	-
sunset red	-	-	■	■	■	■	■	-	-	-
mountain jade green	-	-	■	■	■	■	■	-	-	■

■ available. - not available.
photos not contractually binding

configure and order →

06. customisation

authentic



- eco LED headlamps with LED DRL
- LED tail lamps
- 17.78 cm (7") TFT driver display
- all power windows with auto up/down function



black upholstery with grey stitches



43.18 cm (17") steel wheel with wheel cap

06. customisation

evolution



- LED horizontal rear light bar
- 25.65 cm (10.1") openR link multimedia system
- rear view camera with dynamic guideline & auto zoom
- cruise control



black upholstery with grey stitches



43.18 cm (17") ocean alloy wheels

06. customisation

techno



- full LED headlamps
- electric panoramic sunroof
- electric powered tailgate
- connected car services with My Renault app



brown upholstery with embossed geometrical textile



43.18 cm (17") ocean alloy wheels

06. customisation

techno+



- 26.03 cm (10.25") TFT driver display
- blind spot warning
- front & side parking assist



brown upholstery with embossed geometrical textile



45.72 cm (18") outback diamond cut alloy wheels

06. customisation

iconic



- electric powered front seats with 6-way adjust and manual lumbar support for both driver and passenger
- front ventilated seats
- openR link multimedia system with Google built-in
- 17 advanced driving assistance systems
- hill descent control (DCT only)



mountain jade leatherette upholstery with Renault logo pattern



45.72 cm (18") outback diamond cut alloy wheels

06. customisation

iconic launch edition



- Himalayan inspired side embellisher
- specific iconic yellow door decal
- specific iconic yellow accents on front grille, tailgate and roof bar



mountain jade leatherette upholstery with Renault logo pattern



45.72 cm (18") adventure black alloy wheels



**download the pdf
versions and equipment**

configure and order →

accessories



18" alloy wheel inserts

Designed to fill the wheel arches, the inserts create a broader and more confident look.



air intake garnish - satin chrome

The sleek satin chrome accents bring visual distinction to the vehicle.

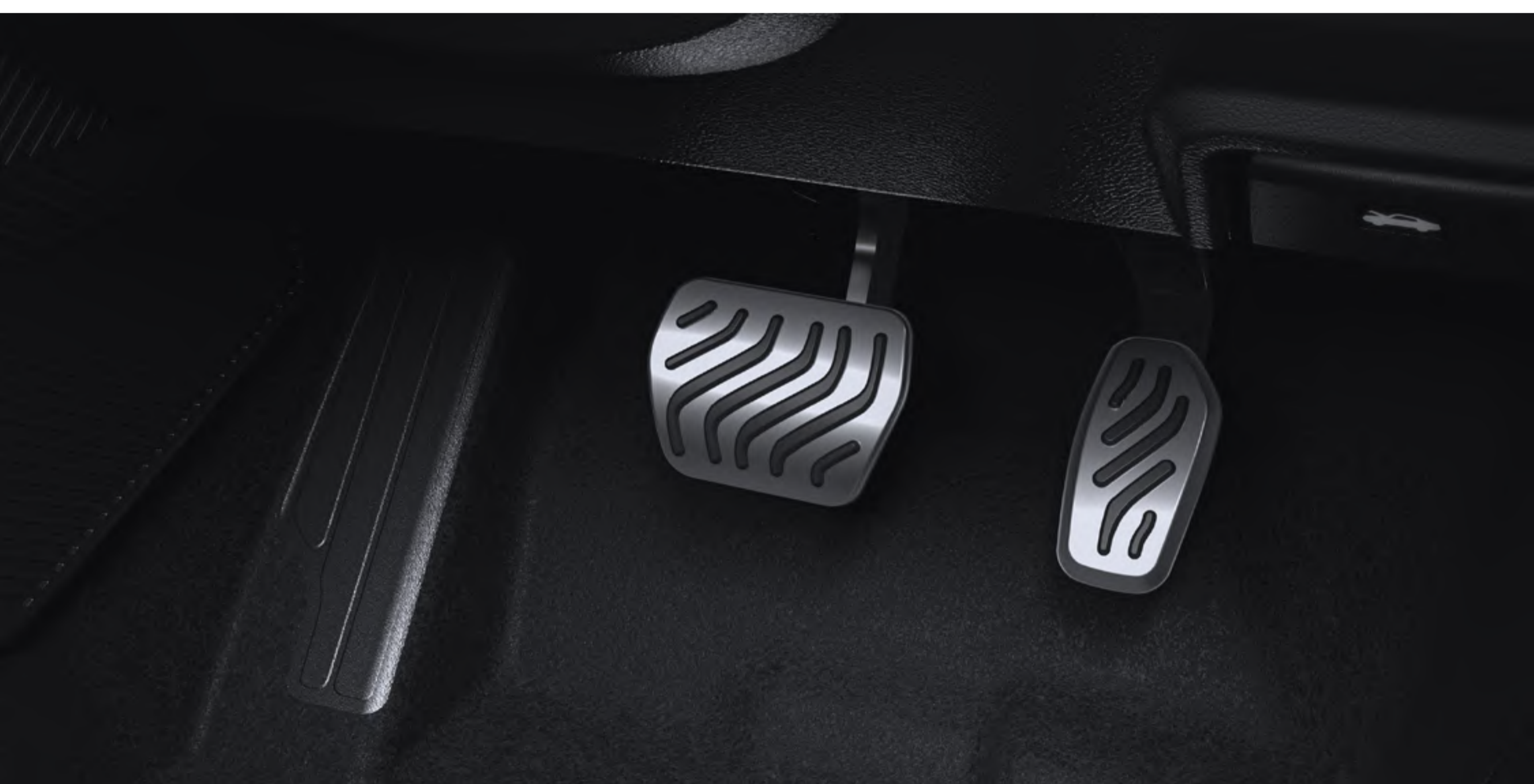

sport pedals

Engineered to deliver a more tactile pedal feel and precise driving control.

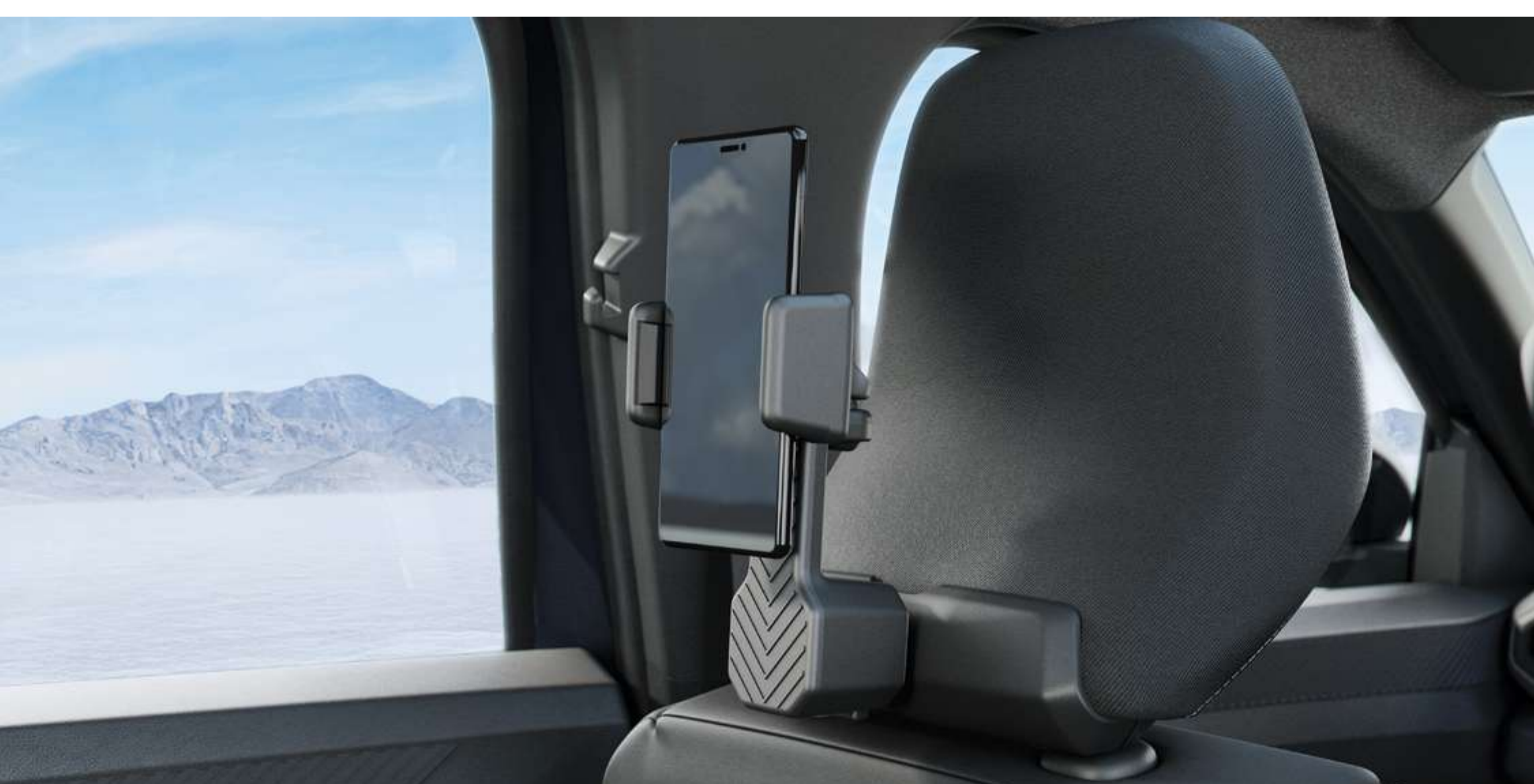

YouClip - smartphone holder

Securely holds your smartphone in place for hands-free navigation and connectivity.



**download the pdf
of the accessories brochure**

configure and order →

06. customisation

engines

Turbo TCe 100 MT	Turbo TCe 160 MT & DCT
fuel	
petrol (E20 compatible)	
max power output (ps @ rpm)	
100 @ 5000	163 @ 5250
max torque (N.m @ rpm)	
166 @ 2000-3750	280 @ 2000-3500
transmission type	
6-speed manual	6-speed manual 6-speed DCT with e-shifter
displacement (cc)	
999	1333
number of cylinders	
3	4



**download the PDF
engines**

dimensions

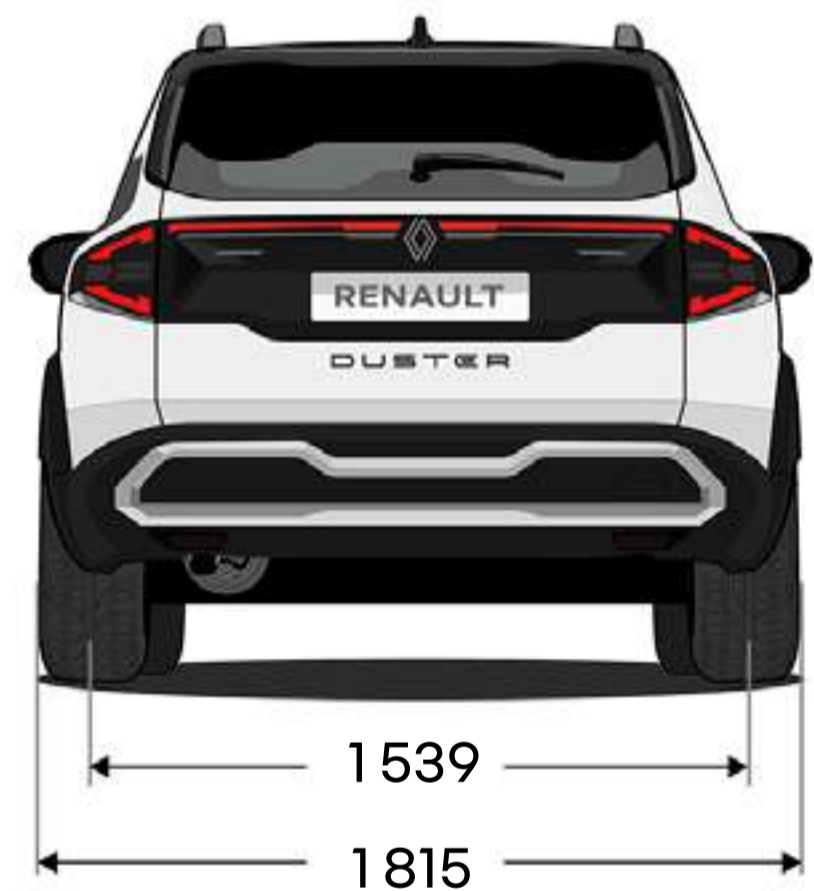
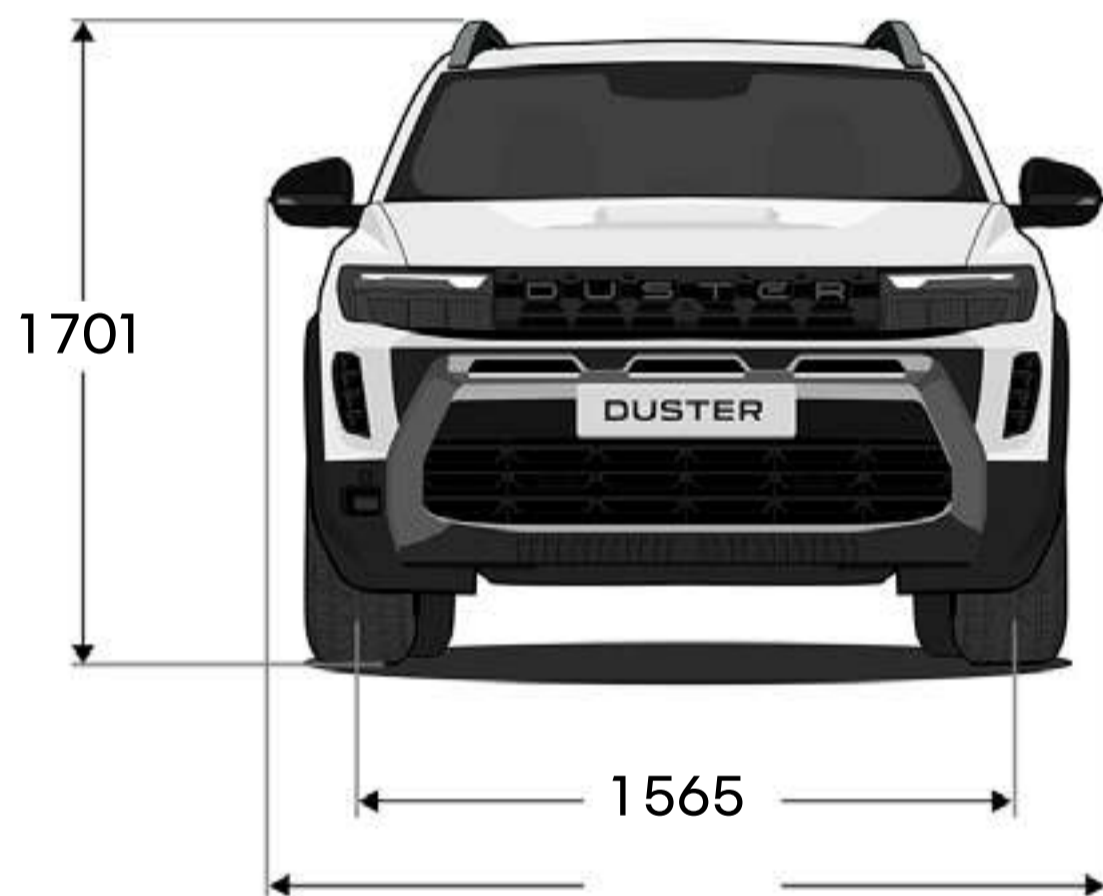
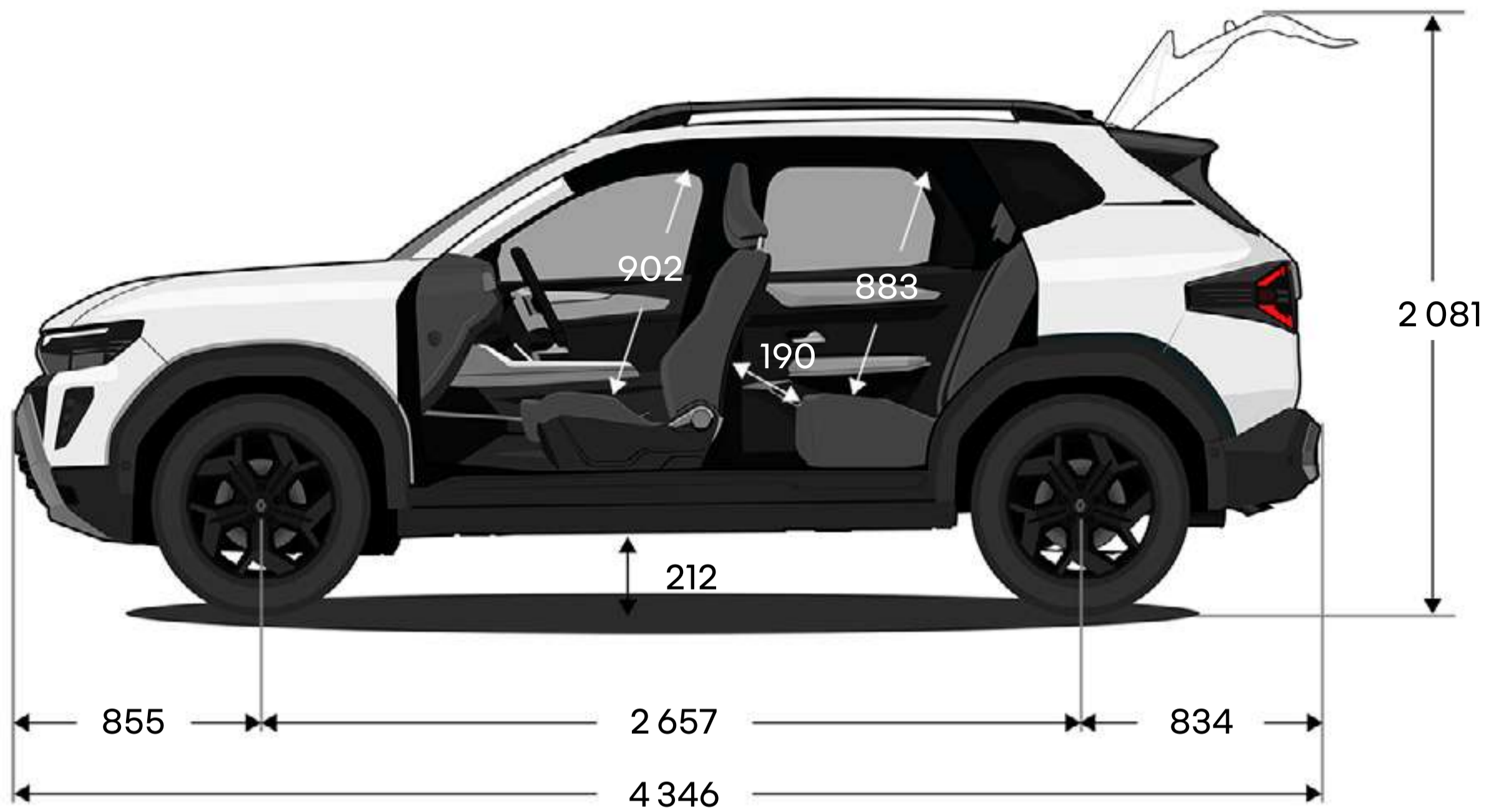

dimensions in mm

[configure and order →](#)

the human first program is a comprehensive safety program developed by Renault in collaboration with researchers, experts and fire-fighters.

because road safety is the business of all road users –be they pedestrians, cyclists or motorists– the human first program by Renault undertakes to:

- 1. prevent accidents by developing safety equipment and advanced driving and safety assistance systems**
17 advanced driver-assistance systems, 6 airbags, child seats (Isofix), Renault's Fixe4sure solution/more than 2,000 safety-related patents filed since 1970
- 2. manage accidents once they have happened by drawing on innovations developed in collaboration with fire-fighters**
QRescue/Fireman Access/more than 5,000 fire-fighters trained over the past 10 years in 20 countries throughout the world/around 400 cars given per year for their training
- 3. reduce the number of accidents and their severity by investing massively in R&D**
safety score/safety coach/connected services/big data/artificial intelligence and cybersecurity systems

[find out more about the human first program](#)

Renault care service

We are always by your side to make your driving experience easier and save you time maintaining your Renault. We'll give you online estimates and appointments, service packages, maintenance contracts, insurance and assistance, the My Renault personalized program and more simple, easy solutions perfectly tailored to your needs.

[find out more about Renault care service](#)



Every precaution was taken to ensure that this brochure was accurate and up-to-date when published. This document has been created using pre-production and prototype models. In line with its policy of continuous product improvement, Renault reserves the right to modify the specifications, vehicles and accessories described and featured at any time. Any such modifications are communicated to Renault dealers as quickly as possible. Depending on the country of sale, versions may differ and some equipment may be unavailable (standard, optional or accessory). Please contact your local dealer for the latest information. For reasons to do with the medium, the colours featured in this document may differ slightly from those of the actual paintwork or interior trim. All rights reserved. Reproduction in any format and by any means of all or part of this brochure is prohibited without prior written authorisation from Renault.

Publicis - photo credits: © Renault Design, © CNCI, ©3DCommerce, © Pagecran - february 2026. Renault s.a.s., a société par actions simplifiée (French simplified joint-stock company) with a share capital of €533,941,113 and head office at 122-122 bis avenue du Général Leclerc 92100 Boulogne-Billancourt Cedex - Nanterre R.C.S. (Trade & Companies Register) B 780 129 987 / Tel.: 0806 00 20 20.

www.renault.co.in
Call. 1800 315 4444

Renault recommends 



[configure and order →](#)